



西菱机床装备世界

WDM Machinery
Equipment the World!

客服热线

400 8658 788

精密立式加工中心、数控钻铣床、高效复合机床、摇臂钻床、立式钻床、台式钻床

www.wddm.com.cn



浙江西菱股份有限公司
ZHEJIANG XILING CO.,LTD.

地址:中国浙江省温岭市泽国镇牧屿机电工业园 邮编(P.C):317521
Add:Xiling Industry Zone of Muyu,Wenling,Zhejiang,China
E-mail: wdm@zjxltz.com



国家级高新技术企业 浙江省著名商标 浙江省名牌产品
State-level-High-Tech Enterprise Zhejiang Famous Trademark Zhejiang Brand Products

WDM[®] 西菱股份
—XILING—

SMART
XILING

西菱--智造钻削技术新典范



www.wddm.com.cn



Z3032X7 Z3032X7P

型号 Model	Z3032 X 7/Z3032 X 7P	
最大钻孔直径 Max. Drilling capacity	mm	31.5
最大攻丝直径 Max. Tapping capacity	mm	铸铁(Cast Iron)20 钢(Steel)16
主轴中心到立柱母线距离 Distance spindle axis to column generating line	mm	300~700
主轴最大行程 Spindle travel	mm	130
主轴转速范围 Spindle speeds range	r/min	100~1600
主轴转速级数 Spindle speeds series	/	8
电动机 Power of main motor	W	750 or 1100
包装尺寸 Packing dimension	cm	126 X 65 X 139/133 X 75 X 149
毛重/净重 G.W/N.W	Kg	415/385 540/500

方柱立式钻床 BOX-TYPE VERTICAL DRILLING MACHINE SERIES

型号 Model	Z5180B	Z5163B
最大钻孔直径 Max. Drilling capacity	mm 80	63
主电机功率 power of main motor	KW 7.5	5.5
主轴锥度 Spindle taper	/ MT6	MT5
主轴行程 Spindle travel	mm 250	250
主轴端面到工作台最大距离 Max. distance from spindle nose to worktable	mm 800(1250)	800(1250)
主轴转速范围(级) Spindle speeds range(steps)	r/min 40~570(9)	40~570(9)
包装尺寸(长X宽X高) Packing dimension(LxWxH)	cm 158X98X280	158X98X280
机床净重 N.W	Kg 1960	1960



Z5163B/Z5180B



Z5140A/Z5150A

型号 Model	Z5140A/Z5150A	Z5140B/Z5150B
最大钻孔直径 Max. Drilling capacity	mm 40/50	40/50
主电机功率 power of main motor	KW 3/4	3/4
主轴锥度 Spindle taper	/ MT4/MT5	MT4/MT5
主轴行程 Spindle travel	mm 250	250
主轴端面到工作台最大距离 Max. distance from spindle nose to worktable	mm 780/740	830
主轴转速范围(级) Spindle speeds range(steps)	r/min 31.5~1400(12)	31.5~1400(12)
包装尺寸(长X宽X高) Packing dimension(LxWxH)	cm 122X80X248 (带电机) 122X80X224 (不带电机)	122X80X248 (带电机) 122X80X224 (不带电机)
机床净重 N.W	Kg 1210	1210

Z5140B/Z5150B

圆柱立式钻床 PILLAR TYPE VERTICAL DRILLING MACHINE



Z5025

Z5025B(台式BENCH)

型号 Model	Z5025B	Z5025
最大钻孔直径 Max. Drilling capacity	mm 25	25
主轴中心到立柱母线距离 Distance spindle axis to column generating line	mm 225	225
主轴最大行程 Spindle travel	mm 150	150
主轴锥度 Spindle taper	/ MT3	MT3
主轴转速范围 Spindle speeds range	r/min 100~2900	100~2900
主电动机 Main motor	KW 1.1/0.75	1.1/0.75
包装尺寸 Packing dimension	cm 74 X 54 X 117	80 X 61 X 190
机床净重 N.W	Kg 225	290

型号 Model	Z5050
最大钻孔直径 Max. Drilling capacity	mm 50
最大攻丝直径 Max. Tapping capacity	mm M30
主轴中心到立柱母线距离 Distance spindle axis to column generating line	mm 360
主轴最大行程 Spindle travel	mm 240
主轴锥度 Spindle taper	/ MT5
主轴转速范围 Spindle speeds range	r/min 42~2050
主电动机 Main motor	KW 2.2/2.8
包装尺寸 Packing dimension	cm 105 X 68 X 259 or 105X68X225
机床净重 N.W	Kg 985



Z5050

型号 Model	Z5040
最大钻孔直径 Max. Drilling capacity	mm 40
最大攻丝直径 Max. Tapping capacity	mm M27
主轴中心到立柱母线距离 Distance spindle axis to column generating line	mm 360
主轴最大行程 Spindle travel	mm 180
主轴锥度 Spindle taper	/ MT4
主轴转速范围 Spindle speeds range	r/min 42~2050
主电动机 Main motor	KW 2.2/2.8
包装尺寸 Packing dimension	cm 105 X 68 X 253 or 105X68X219
机床净重 N.W	Kg 755

Z5040



型号 Model	Z5035	Z5030
最大钻孔直径 Max. Drilling capacity	mm 35	30
最大攻丝直径 Max. Tapping capacity	mm M24	M20
主轴中心到立柱母线距离 Distance spindle axis to column generating line	mm 330	320
主轴最大行程 Spindle travel	mm 150	120
主轴锥度 Spindle taper	/ MT4	MT3
主轴转速范围 Spindle speeds range	r/min 75~2500	65~2600
主电动机 Main motor	KW 1.5/2.2	0.85/1.1
包装尺寸 Packing dimension	cm 98 X 64 X 243 98X64X213	98 X 62 X 226
机床净重 N.W	Kg 545	450



Z5030



Z5035

齿轮式自动进刀钻床 GEAR HEAD AUTO-FEED DRILLING MACHINE

型号 Model		ZS-40B/BP	ZS-40B1/BP1	ZS-40BHS/BPS	ZS-40BHS1/BPS1
最大钻孔直径 Max. Drilling capacity	mm	铸铁(Cast Iron)40 钢(Steel)32		铸铁(Cast Iron)40 钢(Steel)32	
最大攻丝直径 Max. Tapping capacity	mm	铸铁(Cast Iron)M32 钢(Steel)M24		铸铁(Cast Iron)M32 钢(Steel)M24	
主轴中心到立柱母线距离 Distance spindle axis to column generating line	mm	261.5	261.5	261.5	261.5
主轴最大行程 Spindle travel	mm	110	110	110	110
主轴锥度 Spindle taper	/	MT4 or R8	MT4 or R8	MT4 or R8	MT4 or R8
主轴转速范围 Spindle speeds range	r/min	50~1250	50~2500	50~1250	50~2500
主轴进给量 Spindle feeds	mm/r	0.12 0.18 0.25	0.12 0.18 0.25	0.12 0.18 0.25	0.12 0.18 0.25
工作台面尺寸 Dimension of worktable surface	mm	/	/	540 X 470	540 X 470
主电动机 Main motor	W	单相1100 三相1500	单相1100 三相1500	单相1100 三相1500	单相1100 三相1500
包装尺寸 Packing dimension	cm	74 X 64 X 150 74 X 64 X 156	74 X 64 X 156	74 X 64 X 192 74 X 64 X 198	74 X 64 X 198
机床净重 N.W	Kg	290/330	290	390/430	390



ZS-40B/BP ZS-40B1/BP1



ZS-40BHS/BPS ZS-40BHS1/BPS1

钻攻两用钻床 DRILLING&TAPPING MACHINE

ZS-32HS/ZS-32PS

型号 Model		ZS-32HS	ZS-32PS
最大钻孔直径 Max. Drilling capacity	mm	31.5	31.5
最大攻丝直径 Max. Tapping capacity	mm	铸铁(Cast Iron)M20 钢(Steel)M16	
主轴中心到立柱母线距离 Distance spindle axis to column generating line	mm	202	202
主轴最大行程 Spindle travel	mm	130	130
主轴锥度 Spindle taper	/	MT3	MT3
主轴转速 Spindle speeds	r/min	100~2150	100~2150
工作台面尺寸 Dimension of worktable surface	mm	570 X 470	570 X 470
主电动机 Main motor	W	单相1100 三相1500	单相1100 三相1500
包装尺寸 Packing dimension	cm	82 X 75 X 192	84 X 80 X 198
机床净重 N.W	Kg	305	340



ZS-40/ZS-40P

ZS-40HS/ZS-40PS

齿轮式钻攻两用钻床 GEAR HEAD DRILLING&TAPPING MACHINE

型号 Model		ZS-40/ZS-40P	ZS-40HS/ZS-40PS
最大钻孔直径 Max. Drilling capacity	mm	铸铁(Cast Iron)40 钢(Steel)32	
最大攻丝直径 Max. Tapping capacity	mm	铸铁(Cast Iron)M20 钢(Steel)M24	
主轴中心到立柱母线距离 Distance spindle axis to column generating line	mm	272.5	
主轴最大行程 Spindle travel	mm	120	120
主轴锥度 Spindle taper	/	MT4	MT4
主轴转速 Spindle speeds	r/min	95、170、280、540、960、1600	
工作台面尺寸 Dimension of worktable surface	mm	/	570 X 470
主电动机 Main motor	W	单相750 三相1100	单相750 三相1100
包装尺寸 Packing dimension	cm	74 X 64 X 150 / 74 X 64 X 156	74 X 64 X 192 / 74 X 64 X 198
毛重/净重 G.W/N.W	Kg	260/220 290/250	350/310 380/340

自动进刀钻床 AUTO-FEED DRILLING MACHINE

型号 Model		DAF-25B	DAF-25F
最大钻孔直径 Max. Drilling capacity	mm	25	25
主轴中心到立柱母线距离 Distance spindle axis to column generating line	mm	240	235
主轴最大行程 Spindle travel	mm	130	130
主轴进给量 Spindle feeds	mm/r	0.08、0.09、0.10、0.12 0.08、0.10、0.12、0.14	0.08、0.09、0.10、0.12 0.08、0.10、0.12、0.14
主轴锥度 Spindle taper	/	MT3	MT3
主轴转速范围 Spindle speeds range	r/min	300~1540	300~1540
主轴转速级数 Spindle speeds series	/	4级	4级
工作台面尺寸 Dimension of worktable	mm	280X300	370X385or φ420
底座尺寸 Dimension of base	mm	600X350	635X460
总高 Overall height	mm	1180	1720
电动机 Power of main motor	W	750 or 1100	750 or 1100
毛重/净重 G.W/N.W	Kg	150/125	270/240
包装尺寸 Packing dimension	cm	84X52X130	85X52X189



可选工作台
(Choice Table)



DAF-25B

DAF-25F

深孔钻床 LONG TRAVEL DRILLING MACHINE



Z25032

Z20025

型号 Model		Z20025	Z25032
最大钻孔直径 Max. Drilling capacity	mm	25	31.5
最大攻丝直径 Max. Tapping capacity	mm	/	M20/M16
主轴中心到立柱母线距离 Distance spindle axis to column generating line	mm	240	242.5
主轴最大行程 Spindle travel	mm	200	250
主轴锥度 Spindle taper	/	MT3	MT3
主轴转速范围 Spindle speeds range	r/min	290 - 2150	100 - 2150
主轴转速级数 Spindle speeds series	/	5	12
工作台面尺寸 Dimension of worktable surface	mm	/	540 X 470
工作台行程 Table travel	mm	/	515
底座尺寸 Dimension of base	mm	590 X 375	690 X 520
总高 Overall height	mm	930	1810
主电动机 Main motor	W	750(6P)	1500
毛重/净重 G.W/N.W	Kg	155/130	360/320
包装尺寸 Packing dimension	cm	82 X 48 X 102	86 X 78 X 191

钻铣床 DRILLING & MILLING MACHINE



ZX7016



ZX7025

型号 Model		ZX7016	ZX7025	ZX7032
最大钻孔直径 Max. Drilling capacity	mm	16	25	31.5
最大立铣直径 Diameter of vertical milling	mm	10	13	22
最大端铣宽度 Max. face Mill Capacity	mm	40	63	80
主轴中心到立柱母线距离 Distance spindle axis to column generating line	mm	182	240	202
主轴最大行程 Spindle travel	mm	80	110	130
主轴锥度 Spindle taper	r/min	MT2	MT3	MT3
主轴转速范围 Spindle speeds range	mm	320~3300	290~2150	100~2150
工作台面尺寸 Dimension of worktable surface	mm	420X152	555X195	标配730X210 选配820X240
主电动机 Main motor	W	550	750(6P)	单相1100 三相1500
包装尺寸 Packing dimension	cm	88X62X26.5 (carton) 65X58X77 (wood case)	91X67X105	86X74X124 (标配工作台) 92X80X124 (选标工作台)
毛重/净重 G.W/N.W	Kg	100/75	190/160	285/250



ZX7032



ZX7040 B/BI



ZX7045 B/BI

齿轮式自动进刀钻铣床 GEAR HEAD AUTO-FEED DRILLING & MILLING MACHINE

型号 Model		ZX7040B/ ZX7040B1	ZX7045B/ ZX7045B1	ZX7045 (手动)
最大钻孔直径 Max. Drilling capacity	mm	铸铁(Iron)40/ 钢(Steel)32	铸铁(Iron)45/ 钢(Steel)32	45
最大立铣直径 Diameter of vertical milling	mm	22	28	28
最大端铣宽度 Max. face Mill Capacity	mm	80	80	80
主轴中心到立柱母线距离 Distance spindle axis to column generating line	mm	261.5	260	260
主轴最大行程 Spindle travel	mm	110	110	120
主轴锥度 Spindle taper	/	MT4 or R8	MT4 or R8	MT4
主轴转速范围 Spindle speeds range	r/min	50~1250/ 50~2500	50~1250/ 50~2500	95~1600
工作台面尺寸 Dimension of worktable surface	mm	标配730 X 210 选配820 X 240	标配820 X 240 选配730 X 210	标配730 X 210 选配820 X 240
主电动机 Main motor	W	单相1100 三相1500	单相1100 三相1500	单相1100 三相1500
包装尺寸 Packing dimension	cm	96X77X124 (73X21工作台) / 108X77X124 (82X24工作台)		
毛重/净重 G.W/N.W	Kg	340/300	405/330	305/265

ZX7045B/ZX7045B1 带冷却系统 ZX7045B/ZX7045B1 With collant systems

"H" 不带冷却系统 "H" Without collant systems "P" 带冷却系统 "P" With collant systems



ZX7045

型号 Model		ZX-40HC	ZX-40PC
最大钻孔直径 Max. Drilling capacity	mm	铸铁(Cast Iron)40 钢(Steel)32	
最大立铣直径 Diameter of vertical milling	mm	22	22
最大端铣宽度 Width of face milling	mm	80	80
主轴中心到立柱母线距离 Distance spindle axis to column generating line	mm	272.5	272.5
主轴最大行程 Spindle travel	mm	120	120
主轴锥度 Spindle taper	/	MT4	MT4
主轴转速范围 Spindle speeds range	r/min	95~1600	95~1600
工作台面尺寸 Dimension of worktable surface	mm	585 X 190	585 X 190
主电动机 Main motor	W	单相750 三相1100	
包装尺寸 Packing dimension	cm	74 X 72 X 192	74 X 72 X 198
毛重/净重 G.W/N.W	Kg	390/350	415/375



ZX-40HC/ZX-40PC

齿轮式自动进刀钻铣床 GEAR HEAD AUTO-FEED DRILLING & MILLING MACHINE

型号 Model		ZX-40BHC	ZX-40BHC1	ZX-40BPC	ZX-40BPC1
最大钻孔直径 Max. Drilling capacity	mm	铸铁(Cast Iron)40 钢(Steel)32			
最大立铣直径 Diameter of vertical milling	mm	22	22	22	22
最大端铣宽度 Width of face milling	mm	80	80	80	80
主轴中心到立柱母线距离 Distance spindle axis to column generating line	mm	261.5	261.5	261.5	261.5
主轴最大行程 Spindle travel	mm	110	110	110	110
主轴锥度 Spindle taper	/	MT4 or R8	MT4 or R8	MT4 or R8	MT4 or R8
主轴转速范围 Spindle speeds range	r/min	50~1250	50~2500	50~1250	50~2500
工作台面尺寸 Dimension of worktable surface	mm	585 X 190	585 X 190	585 X 190	585 X 190
主电动机 Main motor	W	单相1100 三相1500			
包装尺寸 Packing dimension	cm	74 X 72 X 192	74 X 72 X 198	74 X 72 X 192	74 X 72 X 198
毛重/净重 G.W/N.W	Kg	410/370 or 380/340			



ZX-32HC



ZX-32PC



ZX-40BHC/BPC ZX-40BHC1/BPC1

型号 Model		ZX-32HC	ZX-32PC
最大钻孔直径 Max. Drilling capacity	mm	31.5	31.5
最大立铣直径 Diameter of vertical milling	mm	22	22
最大端铣宽度 Width of face milling	mm	80	80
主轴中心到立柱母线距离 Distance spindle axis to column generating line	mm	202	202
主轴最大行程 Spindle travel	mm	130	130
主轴锥度 Spindle taper	/	MT3	MT3
主轴转速范围 Spindle speeds range	r/min	100~2150	100~2150
工作台面尺寸 Dimension of worktable surface	mm	585 X 190	585 X 190
主电动机 Main motor	W	单相1100 三相1500	
包装尺寸 Packing dimension	cm	74 X 72 X 192	74 X 72 X 198
净重 N.W	Kg	420/380	445/405



ZD系列精品工业台钻

Series Accuracy Bench Drilling Machine

机床优点:

- 主轴箱，立柱及底座均采用优质铸铁，并经时效处理，稳重结实，经久耐用；
- 高精度，高转速，广泛应用于仪器，仪表及照相机等行业。



手柄杆(整体钢件)
FEED HANDLE (STEEL MATERIAL)

套筒导向装置
QUILL ORIENTATION MECHANISM

LED工作灯
LED LIGHT

皮带张紧机构
BELT ADJUST MECHANISM



ZD系列精品钻攻两用台钻 ZD SERIES ACCURACY DRILLING&TAPPING MACHINE



ZS4112D/ZS4116D



ZS4120D/ZS4125D

型号 Model		ZS4112D/ZS4116D	ZS4120D/ZS4125D
最大钻孔/攻丝直径 Max. Drilling/Tapping capacity	mm	D:12/T:M10/M8 D:16/T:M12/M10	D:20/T:M20/M16 D:25/T:M24/M20
主轴中心到立柱母线距离 Distance spindle axis to column generating line	mm	193	240
主轴最大行程 Spindle travel	mm	100	125
主轴锥度 Spindle taper	/	B16/MT2	MT2/MT3
主轴转速范围 Spindle speeds range	r/min	480~4100	290~2150
工作台面尺寸 Dimension of work table surface	mm	200 X 230	280 X 300
电动机 Power of motor	W	550/750	750/1100 (6级、6P)
包装尺寸 Packing dimension	cm	77 X 42 X 96	83 X 47 X 104
机床净重 Net weight	Kg	90	140

ZD系列精品工业台钻 ZD SERIES ACCURACY BENCH DRILLING MACHINE



Z512-2D/Z516-2D



Z512D/Z516D



Z4120D/Z4125D

型号 Model		Z512-2D/Z516-2D	Z512D/Z516D	Z4120D/Z4125D
最大钻孔直径 Max. Drilling capacity	mm	12.7/16	12.7/16	20/25
主轴中心到立柱母线距离 Distance spindle axis to column generating line	mm	193	193	240
主轴最大行程 Spindle travel	mm	100	100	125
主轴锥度 Spindle taper	/	B16/B18	B16/MT2	MT2/MT3
主轴转速范围 Spindle speeds range	r/min	480~4100	480~4100	365~3150
电动机 Power of motor	W	370/550	370/550	750/1100
包装尺寸 Packing dimension	cm	77 X 42 X 96	80X45X95 / 77 X 42 X 96	83 X 47 X 104
机床净重 Net weight	Kg	90	90	140

ZQD SERIES LIGHT TYPE DRILL PRESS ZQD系列轻型钻床

特点:

- 轻便灵活, 可供机加, 修理等行业, 也适用于家庭中修理日用机具等。

Characters:

- Light and flexible, it can be used not only on machine processing, repairing but also DIY repairing and daily use.

ZQ4116D/ZQ4119D

ZQD4125D/ZQD4132D



HIGH-SPEED ACCURACY BENCH DRILLING MACHINE 高速精密台钻

机床优点:

- 主轴箱, 立柱及底座均采用优质铸铁, 并经时效处理, 稳重结实, 经久耐用;
- 高精度, 高转速, 广泛应用于仪器, 仪表及照相机等行业。

Characters:

- Both spindle head, column and base using high quality cast iron, strong and everlasting.
- High precision with excellent feature, widely used in instrument and camera area.



Z406BD/Z406CD



型号 Model		ZQ4113D	ZQ4116D/ZQ4119D	ZQ4125D	ZQD4125D ZQD4132D
最大钻孔直径 Max. Drilling capacity	mm	13	16/19	25	25/31.5
立柱直径 Diameter of column	mm	70	70	85	85
主轴最大行程 Spindle travel	mm	85	85	110	110
主轴中心至立柱母线距离 Distance spindle axis to column generating line	mm	180	180	200	200
主轴端至工作台面最大距离 Max. Distance spindle nose to table	mm	390	410	480	390
主轴端至底座台面最大距离 Max. Distance spindle nose to base	mm	570	590	670	1140
主轴锥度 Spindle taper		B16	MT2	MT3	MT3
主轴转速范围 Spindle speeds range	r/min	495~2565	270~2880	200~2280	200~2280 150~2270
主轴转速级数 Spindle speeds series		4	12	9/12	9/12
工作台面尺寸 Dimension of table surface	mm	240X 240 or Φ300	240X 240 or Φ300	280X 280 or Φ360	280X 280 or Φ360
底座尺寸 Dimension of base	mm	445 X 270	445 X 270	566 X 356	566 X 356
总高 Overall height	mm	960	960	1110	1680
电动机 Power of motor	W	370	370/550	750	750
毛重/净重 G.W/N.W	kg	68/65	68/65	105/98	115/108
包装尺寸 Packing dimension	cm	91 X 51.5 X 27	91 X 51.5 X 27	108 X 77 X 34	108 X 77 X 34

型号 Model		Z406CD	Z406BD
最大钻孔直径 Max. Tapping capacity	mm	6	6
立柱直径 Diameter of column	mm	50	50
主轴最大行程 Spindle travel	mm	65	65
主轴中心至立柱母线距离 Distance spindle axis to column generating line	mm	140	140
主轴端至工作台面最大距离 Max. Distance spindle nose to table	mm	/	/
主轴端至底座台面最大距离 Max. Distance spindle nose to base	mm	225	225
主轴锥度 Spindle taper		B10	B10
主轴转速范围 Spindle speeds range	r/min	1400~5800	2000~12000
主轴转速级数 Spindle speeds series		3	3
工作台面尺寸 Dimension of worktable surface	mm	/	/
底座尺寸 Dimension of base	mm	380 X 258	380 X 258
总高 Overall height	mm	605	605
电动机 Power of motor	W	250	250/370
毛重/净重 G.W/N.W	kg	48/38	48/38
包装尺寸 Packing dimension	cm	61 X 30 X 54	61 X 30 X 54



ZB 系列高标准强力型自动进刀钻床

Series Premium Standard Heavy Duty Automatic Feed Drilling Machine

机床优点:

- 外形美观、大方、新颖，结构合理、刚性高、强度高；
- 主轴行程大、加工范围广；
- 工作台可上下升降、可360度回转，操作省力；
- 功能齐全；带攻丝功能、带U型眼护罩、皮带罩可带开门断电功能、可带特殊附件；多轴器等；
- 主轴箱、工作台、立柱、底座采用优质铸铁，并经时效处理，稳重结实，经久耐用；
- 主轴、花键套、齿轮轴经过热处理工艺，强度高。
- 机床转速及进给均有广泛的变速范围，可进行机动、手动操控，可随时轻便地接通或切断进给；



手柄杆(整体钢件)
FEED HANDLE (STEEL MATERIAL)



套筒导向装置
QUILL ORIENTATION MECHANISM



LED工作灯
LED LIGHT



皮带张紧机构
BELT ADJUST MECHANISM



控制面板
CONTROL FRONT PANEL



主轴进给速度无机可调
THE SPEED OF SPINDLE FEEDS INFINITELY ADJUSTABLE



➤➤➤ ZB 高标准强力型自动进刀钻床 ZB PREMIUM STANDARD HEAVY DUTY AUTOMATIC FEED DRILLING MACHINE



ZB4120G



ZB4132G



ZB4116G

型号Model		ZB4132G	ZB4120G	ZB4116G
最大钻孔直径 Max.Drilling capacity	mm	φ 31.75 (铸件)	φ 20 (铸件)	φ 16 (铸件)
最大攻丝直径 Max.tappingcapacity	mm	M24 (铸件) M20 (铸件)	M20 (铸件) M16 (铸件)	M12 (铸件) M10 (铸件)
主轴最大行程 Spindle travel	mm	150	135	100
主轴中心到立柱母线距离 Distance spindle axis to column generating line	mm	265	260	193
主轴端面至工作台面最大距离 Max.Distance spindle nose to table	mm	390	366	330
主轴端面至底座台面最大距离 Max .Distance spindle nose to base	mm	745	678	613
主轴锥度 Spindle taper	/	MT3	MT2	MT2
工作台面尺寸 Dimension of worktable surface	mm	380 x 400	300 x 320	265 x 285
电动机功率 Motor	KW	1.5	1.1	0.75
机床净重 Net weight	Kg	238	183	153
包装尺寸 Packing dimension	mm	1040 x 640 x 1510	990 x 590 x 1400	850 x 540 x 1280



G系列新型强力钻床 Series Bench Strong Drilling Machine

机床优点:

- 外形美观、大方、新颖;
- 结构合理、刚性好、强度高;
- 主轴形成大、加工范围广;
- 工作台可上升下降、可360度回转,操作省力;
- 功能齐全;带攻丝功能、带U型眼护罩、皮带罩可带开门断电功能、可带特殊附件;多轴器等;
- 主轴箱、工作台、立柱、底座采用优质铸铁,并经时效处理,稳重结实,经久耐用;
- 主轴、花键套、齿轮轴经过热处理工艺,强度高。



控制面板
CONTROL FRONT PANEL

套筒导向装置
QUILL ORIENTATION MECHANISM



LED工作灯
LED LIGHT



工作台升降机构
WORKTABLE UP/DOWN MECHANISM



手柄杆(整体钢件)
FEED HANDLE (STEEL MATERIAL)



皮带张紧机构
BELT ADJUST MECHANISM



▶▶▶▶ G系列高标准强力型钻床 G SERIES PREMIUM STANDARD HEAVY DUTY DRILLING MACHINE



Z4132G



Z4120G



Z4116G



Z4006G (高速台钻)

型号Model			Z4132G	Z4120G	Z4116G	Z4006G
最大钻孔直径 Max. Drilling capacity	mm		Φ31.75	Φ20(钢件)	Φ16	Φ6(钢件)
最大攻丝直径 Max. Tapping capacity	mm		M24(铸铁)/M20(钢件)	M20(铸铁)/M16(钢件)	M12(铸铁)/M10(钢件)	/
主轴中心到立柱母线距离 Distance spindle axis to column generating line	mm		265	260	193	140
主轴最大行程 Spindle travel	mm		150	135	100	65
主轴锥度 Spindle taper	/		MT3	MT2	Mt2	B10
工作台面尺寸 Dimension of worktable surface	mm		380x400	300x320	265x285	/
电动机功率 Motor	KW		1.5 (6P)	1.1(6P)	0.75(4P)	0.37(2P)
机床净重 Net weight	Kg		225	170	145	55
包装尺寸 Packing dimension	mm		1040x640x1510	990x560x1400	850x540x1280	640x350x580



SWJ 系列新型攻丝机 NEW TYPE SWJ TAPPING MACHINE SERIES



SWJ-6D/SWJ-12D



SWJ-16D



SWJ-24D

型号 Model		SWJ-6D/SWJ-12D	SWJ-16D	SWJ-24D
最大攻丝直径 Max. Tapping capacity (HT200/45)	mm	M6/M5, M12/M8	M16/M12	M24/M20
主轴最大行程 Spindle travel	mm	40	50	50
主轴中心至立柱母线距离 Distance spindle axis to column generating line	mm	127	183	198
主轴端至工作台面最大距离 Max. Distance spindle nose to table	mm	245/240	485	545
主轴端至底座工作台面最大距离 Max. Distance spindle nose to base	mm	375/370	660	760
主轴锥度 Spindle taper	/	B12/B16	B18	B22
工作台面尺寸 Dimension of worktable surface	mm	195 X 195/235 X 235	270 X 280	280 X 280
电动机 Power of motor	KW	0.37/0.55	0.75	1.1
毛重/净重 G.W/N.W	Kg	63/43 70/50	120/102	160/140
包装尺寸 Packing dimension	cm	58 X 37 X 90	68 X 42 X 128	78 X 48 X 116

SWJ 系列攻丝机 SWJ SERIES TAPPING MACHINE



SWJ-10B



SWJ-6/SWJ-12



SWJ-16



SWJ-24

型号 Model		SWJ-10B	SWJ-6/SWJ-12	SWJ-16	SWJ-24
最大攻丝直径 Max. Tapping capacity (HT200/45)	mm	M12/M10	M6/M5, M12/M8	M16/M12	M24/M20
主轴最大行程 Spindle travel	mm	50	40	50	50
主轴锥度 Spindle taper	/	B16	B12/B16	B18	B22
主轴中心至立柱母线距离 Distance spindle axis to column generating line	mm	140	127	183	198
主轴端至工作台面最大距离 Max. Distance spindle nose to table	mm	265	245/240	485	545
主轴端至底座工作台面最大距离 Max. Distance spindle nose to base	mm	/	375/370	660	760
工作台面尺寸 Dimension of worktable surface	mm	200 X 200	195X 195/235 X 235	270 X 280	280 X 280
电动机 Power of motor	W	550	370/550	0.75	1.1
毛重/净重 G.W/N.W	Kg	74/60	63/43, 70/50	120/102	160/140
包装尺寸 Packing dimension	cm	59 X 37 X 74	58 X 37 X 90	68 X 42 X 128	78 X 48 X 116

钻攻两用机 DRILLING&TAPPING MACHINE



ZQS4116 钻攻两用机



ZS4112C/ZS4116B 钻攻两用机



ZS4120/ZS4125 钻攻两用机

型号 Model		ZQS4116	ZS4112C ZS4116B	ZS4120 ZS4125
最大钻孔/攻丝直径 Max. Drilling/Tapping capacity	mm	D:16/T:M12/M10	D:12/T:M10/M8 D:16/T:M12/M10	D:20/T:M20/M16 D:25/T:M24/M20
主轴最大行程 Spindle travel	mm	85	100	125
主轴中心至立柱母线距离 Distance spindle axis to column generating line	mm	180	193	240
主轴锥度 Spindle taper	/	MT2	B16/MT2	MT2/MT3
工作台面尺寸 Dimension of work table surface	mm	240 X 240 or φ300	200 X 230	280 X 300
电动机 Power of motor	W	550	550/750	750/1100 (6级、6P)
毛重/净重 G.W/N.W	Kg	75/65	108/90	165/140
包装尺寸 Packing dimension	cm	70 X 40 X 104	77 X 42 X 95	82 X 48 X 102

高速精密台钻 HIGH-SPEED ACCURACY BENCH DRILLING MACHINE

型号 Model		Z406	Z406C	Z406B
最大钻孔直径 Max. Tapping capacity	mm	6	6	6
主轴中心至立柱母线距离 Distance spindle axis to column generating line	mm	140	140	140
主轴最大行程 Spindle travel	mm	65	65	65
主轴锥度 Spindle taper	/	B10	B10	B10
主轴转速范围 Spindle speeds range	r/min	1400~5800	1400~5800	2000~12000
电动机 Power of motor	W	250	250	250/370
毛重/净重 G.W/N.W	Kg	48/38	48/38	48/38
包装尺寸 Packing dimension	cm	62 X 32 X 55	62 X 32 X 55	62 X 32 X 55



Z406



Z406B



Z406C



ZWG-4



ZWG-6

型号 Model		ZWG-4	ZWG-6
最大钻孔直径 Max. Tapping capacity	mm	4	6
主轴中心至立柱母线距离 Distance spindle axis to column generating line	mm	125	140
主轴最大行程 Spindle travel	mm	50	55
主轴锥度 Spindle taper	/	B6 or JTO	B10
主轴转速范围 Spindle speeds range	r/min	2800~11500	6700~15000
电动机 Power of motor	W	120	370
毛重/净重 G.W/N.W	Kg	32/28	50/40
包装尺寸 Packing dimension	cm	36 X 32 X 66	56 X 30 X 60

十字拖板



ZX7020(CT4916)



ZX7025(CT5519)



ZX7025A(CT6420)



CT9032

特殊附件
Special accessories



无级调速卧式走刀器
Horizontal speed variable power table feed



无级调速立式走刀器
Vertical speed variable power table feed

型号 Model		ZX7020 (CT4916)	ZX7025 (CT5519)	ZX7025A (CT6420)	CT9032
工作台尺寸(纵向L X 横向W) Dimension of worktable	mm	495 X 165	555 X 195	640 X 205	900 X 320
工作台纵向行程 Longitudinal travel of worktable	mm	210	240	370	400
工作台横向行程 Transverse travel of worktable	mm	100	140	150	320
底板尺寸(纵向L X 横向W) Dimension of base	mm	260 X 280	335 X 315	238 X 320	650 X 400
安装孔/槽中心距(纵向 X 横向) Distance of mounting bores/slots	mm	180 X 140	260 X 170	288	360 X 320
安装孔/槽尺寸 Size of mounting bores/slots	mm	4-Φ13孔(Hole)	4-Φ13孔(Hole)	2-12腰形槽(Slot)	4-Φ15
毛重/净重 G.W./N.W.	Kg	40/36	50/45	65/60	280/250
包装尺寸 Packing dimension	cm	69 X 44 X 20	76 X 53 X 20	95 X 50 X 25	118 X 82 X 34

导螺杆攻牙动力头 GUIDE SCREW TAPPING HEAD

型号 Model	GTH7-80	
最大攻牙能力 Max.Tapping Capacity	mm	M30
主轴锥度 Spindle taper	/	MT3或ER32
主轴行程 Spindle travel	mm	80
主轴转速 Spindle speeds	r/min	客户指定(Customer specified)
螺纹导程 Screw thread travel	mm	0.7-2.5
主轴传动 Spindle transmission	/	导螺杆(Guide screw)



GTH7-80

油压钻孔动力头 OIL PRESSURE DRILLING HEAD



ODH6-130

型号 Model	ODH6-130	
最大钻孔能力 Max.Drilling Capacity	mm	φ 15
主轴锥度 Spindle taper	/	JT6或ER32
主轴行程 Spindle travel	mm	125
主轴转速 Spindle speeds	r/min	客户指定(Customer specified)
油缸直径 Diameter of oil tank	mm	φ 75
使用压力 Work pressure	Kg/cm ²	20-35



型号 Model	ODH8-150	
最大钻孔能力 Max.Drilling Capacity	mm	φ 35
主轴锥度 Spindle taper	/	MT4或ER40
主轴行程 Spindle travel	mm	140
主轴转速 Spindle speeds	r/min	客户指定(Customer specified)
油缸直径 Diameter of oil tank	mm	φ 110
使用压力 Work pressure	Kg/cm ²	20-35



ODH8-150

多轴器 MULTI-SPINDLE DRILLING HEAD



T108
T125
T200



FT125
FT200
FT300
FT400



FA135
FA200
FA250



FU110
FU165
FU200
FU250
FU300

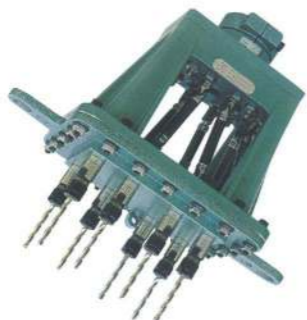

FU110X165
FU120X200
FU220X360



FB130
FB170
FB210

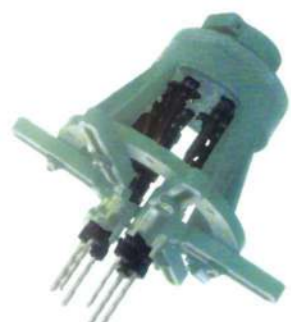

U110
U165
U200
U250
U300

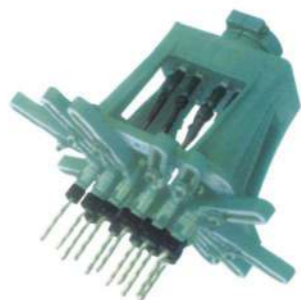

U110X165
U120X200
U220X360



西菱机床装备世界

WDM Machinery
Equipment the World!

www.wddm.com.cn

攻丝机床 TAPPING MACHINE



特殊附件
(Special accessories)

导螺杆自动进刀攻丝机 LEAD-SCREW AUTOMATIC TAPPING MACHINE

型号 Model	SB8030	
最大攻丝直径Max.Tapping capacity	mm	M30
主轴最大行程Spindle travel	mm	80
主轴锥度Spindle taper	/	MT3或(or)ER32
主轴转速Spindle speeds	r/min	客户指定 (Customer specified)
电动机Power of main motor	KW	2.2
包装尺寸Packing dimension	cm	1000×850×2100
机床净重 N.W	Kg	475

SB8030

特殊附件
(Special accessories)



SB6532
带机架(with stand)

齿轮式牙距自动攻丝机 GEAR TYPE TEETH DISTANCE TAPPING MACHINE

型号 Model	SB6532	SB6532A	
最大攻丝直径Max.Tapping capacity	mm	M32	M32
主轴最大行程Spindle travel	mm	65	65
主轴锥度Spindle taper	/	MT3	MT3
主轴转速Spindle speeds	r/min	80、150、280(6P电机Motor)或 120、220、420(4P电机Motor)	80、150、280(6P电机Motor)或 120、220、420(4P电机Motor)
电动机Power of main motor	KW	1.5(6P)/2.2kW(4P)	1.5(6P)/2.2kW(4P)
包装尺寸Packing dimension	cm	无机架 102×62×135 带机架 151×121×225	56×53×70
机床净重 N.W	Kg	无机架 350 带机架 600	130



SB408 SB4516
无机架(without stand)



SB4516A
(卧式 Horizontal)



SB6532A
(卧式 Horizontal)

特殊附件
(Special accessories)



SB408 SB4516
带机架(with stand)

齿轮式牙距自动攻丝机 GEAR TYPE TEETH DISTANCE TAPPING MACHINE

型号 Model	SB408	SB4516	SB4516A	
最大攻丝直径Max.Tapping capacity	mm	M8	铸件(Cast Iron)M16×1.5/钢(Steel)M12×1.5	
主轴最大行程Spindle travel	mm	45	45	
主轴锥度Spindle taper	/	B16	B18	
主轴转速Spindle speeds	r/min	360、590、960(6P电机Motor)或 540、655、1445(4P电机Motor)	360、590、960(6P电机Motor)或 540、655、1445(4P电机Motor)	360、590、960(6P电机Motor)或 540、655、1445(4P电机Motor)
电动机Power of main motor	KW	0.55(6P)/0.75(4P)	0.55(6P)/0.75(4P)	0.55(6P)/0.75(4P)
包装尺寸Packing dimension	cm	无机架74×44×90 机架90×58×146	无机架74×44×90 机架80×63×84	56×53×70
机床净重 N.W	Kg	无机架 105 机架 160	无机架 115 机架 160	65

双头组合钻床 DOUBLE-SPINDLE COMPOUND MACHINE

双头多用机床 DOUBLE-SPINDLE COMPOUND MACHINE

型号 Model	ZXSM-45	ZXSM-45A	
最大钻孔直径 Max.Drilling capacity	mm	40钢/45铸件	40钢/45铸件
最大攻丝直径 Max.Tapping capacity	mm	M32钢/M40铸件	M32钢/M40铸件
主轴中心到立柱母线距离 Distance spindle axis to column generating line	mm	275	275
主轴最大行程 Spindle travel	mm	90	120
主轴锥度 Spindle taper	/	MT3	MT4
主轴转速 Spindle speeds	r/min	钻(Drill): 75、130、240、390、670、1200 攻、铰(Tap、ream): 35、65、120、190、330、600	
工作台面尺寸 Dimension of worktable surface	mm	800 X 240	1000 X 240
电动机 Motor	KW	2.2	2.2
包装尺寸 Packing dimension	cm	108 X 89 X 196	109 X 109 X 210
机床净重 N.W	Kg	500	600



ZH30

液压滑台式动力头自动钻攻两用机床 COMPOUND MACHINE WITH DRILLING AND TAPPING HEAD

型号 Model	ZH30	
最大攻丝直径 Max.Tapping capacity	mm	M20
最大钻孔直径 Max.Drilling capacity	mm	30
主轴中心到立柱母线距离 Distance spindle axis to column generating line	mm	350
主轴最大行程 Spindle travel	mm	80/140
主轴锥度 Spindle taper	/	MT3/MT4
主轴转速范围 Spindle speeds range	r/min	0~930 (攻丝) 0~1420 (钻孔)
工作台面尺寸 Dimension of worktable surface	mm	400×300
主电动机 Main Motor	KW	2.2/4
包装尺寸 Packing dimension	cm	215×136×263
机床净重 N.W	Kg	1800



ZXSM-45/ZXSM-45A



双头组合机床 DOUBLE-SPINDLE COMPOUND MACHINE

型号 Model	ZXS4625	
最大钻孔直径 Max.Drilling capacity	mm	25
最大攻丝直径 Max.Tapping capacity	mm	M24/M20
主轴中心到立柱母线距离 Distance spindle axis to column generating line	mm	240
最大端铣宽度 Max.Face Mill capacity	mm	63
最大立铣宽度 Diameter of vertical milling	mm	13
主轴最大行程 Spindle travel	mm	125/110
主轴锥度 Spindle taper	/	MT3
主轴转速范围 Spindle speeds range	r/min	290~2150
电动机 Motor	W	750(6P)
包装尺寸 Packing dimension	cm	94 X 84 X 105
机床净重 N.W	Kg	280



ZXS4625

油压自动进刀动力头钻床 DRILLING MACHINE WITH OIL PRESSURE AUTOMATIC FEED UNIT



油压精密分度盘
Oil pressure precision index plate

特殊附件
(Special accessories)

型号 Model	OD-35	
最大钻孔直径 Max. Drilling capacity	mm	35
主轴中心到立柱母线距离 Distance spindle axis to column generating line	mm	282.5
主轴最大行程 Spindle travel	mm	140
主轴锥度 Spindle taper	/	MT4或ER40
主轴转速范围 Spindle speeds range	r/min	客户指定(Customer specified)
冷却泵电机 Coolant motor	W	40
主电动机功率 Power of Main motor	KW	2.2/4
包装尺寸 Packing dimension	mm	121 x 150 x 225
机床净重 N.W	Kg	600



Z3080X25

摇臂钻 RADIAL DRILLING MACHINE



Z3063X20A

型号 Model	Z3080 X 25	Z3063 X 20A	
最大钻孔直径 Max. Drilling capacity	mm	80	63
主轴中心到立柱母线距离 Distance spindle axis to column generating line	mm	500~2500	450~2050
主轴最大行程 Spindle travel	mm	450	400
主轴锥度 Spindle taper	/	MT6	MT5
主轴转速范围 Spindle speeds range	r/min	16~1250	20~1600
主电动机功率 Power of Main motor	KW	7.5	5.5
包装尺寸 Packing dimension	cm	395 X 162 X 219 380 X 154 X 153	348 X 147 X 214
毛重/净重 G.W/N.W	Kg	11250/10500	7115/6765



Z3040X16/1 Z3050X12/1 Z3050X16/1 ZQ3050X20/1

型号 Model	Z3040X16/1	Z3050X16/1	ZQ3050X20/1	Z3050X12/1
最大钻孔直径 Max. Drilling capacity	mm	40/50	50	50
主轴中心到立柱母线距离 Distance spindle axis to column generating line	mm	350~1600	350~2000	350~1250
主轴锥度 Spindle taper	/	MT4/MT5	MT5	MT5
主轴最大行程 Spindle travel	mm	315	315	315
主轴转速范围 Spindle speeds range	r/min	25~2000	25~2000	25~2000
主电动机功率 Power of Main motor	KW	3/4	4	4
包装尺寸 Packing dimension	cm	278X112X254	316X112X254	240X112X252
毛重/净重 G.W/N.W	Kg	3800/3550	3960/3660	3560/3310



Z3040X13/1

型号 Model	Z3040X13/1	
最大钻孔直径 Max. Drilling capacity	mm	40
主轴中心到立柱母线距离 Distance spindle axis to column generating line	mm	300~1300
主轴锥度 Spindle taper	/	MT4
主轴最大行程 Spindle travel	mm	280
主轴转速范围 Spindle speeds range	r/min	32~2500
主电动机功率 Power of Main motor	KW	3
包装尺寸 Packing dimension	cm	235 X 106 X 243
毛重/净重 G.W/N.W	Kg	2500/2100

型号 Model	Z3032X10	Z3040 X 10
最大钻孔直径 Max. Drilling capacity	mm	32/40
主轴中心到立柱母线距离 Distance spindle axis to column generating line	mm	200~1000
主轴锥度 Spindle taper	/	MT4
主轴最大行程 Spindle travel	mm	250
主轴转速范围 Spindle speeds range	r/min	71~1800
主电动机功率 Power of Main motor	KW	2.2/3
包装尺寸 Packing dimension	cm	190 X 86 X 228
毛重/净重 G.W/N.W	Kg	1570/1500



Z3040X10 Z3032X10

型号 Model	Z3032X8/1	Z3040X8/1	Z3032X10/1	Z3040X10/1	ZQ3040X10/1
最大钻孔直径 Max. Drilling capacity	mm	32/40	32/40	40	40
主轴中心到立柱母线距离 Distance spindle axis to column generating line	mm	320~820	300~1000	320~1020	320~1020
主轴锥度 Spindle taper	/	MT4	MT4	MT4	MT4
主轴最大行程 Spindle travel	mm	240	280	240	240
主轴转速范围 Spindle speeds range	r/min	75~1220	32~2500	75~1220	75~1220
主电动机功率 Power of Main motor	KW	1.5	2.2	1.5	1.5
包装尺寸 Packing dimension	cm	160 X 82 X 208	190X92X228	180X82X208	180X82X208
毛重/净重 G.W/N.W	Kg	1280/1190	1690/1600	1300/1210	1300/1210



Z3032X8/1 Z3040X8/1



Z3032X10/1 Z3040X10/1 ZQ3040X10/1



西菱机床装备世界

WDM Machinery
Equipment the World!

客服热线

400 8658 788

精密立式加工中心、数控钻铣床、高效复合机床、摇臂钻床、立式钻床、台式钻床

www.wddm.com.cn



浙江西菱股份有限公司
ZHEJIANG XILING CO.,LTD.

地址:中国浙江省温岭市泽国镇牧屿机电工业园 邮编(P.C):317521
Add:Xiling Industry Zone of Muyu,Wenling,Zhejiang,China
E-mail: wdm@zjxltz.com



国家级高新技术企业 浙江省著名商标 浙江省名牌产品
State-level-High-Tech Enterprise Zhejiang Famous Trademark Zhejiang Brand Products

WDM[®] 西菱股份
—XILING—

SMART
XILING

西菱--智造钻削技术新典范

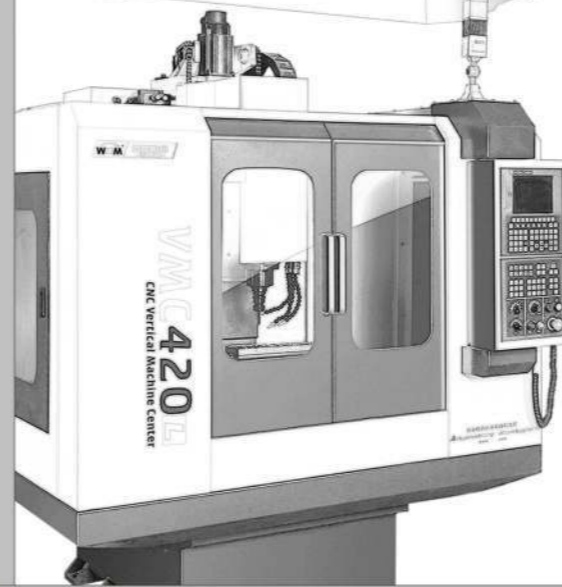

www.wddm.com.cn